

Personnel Positioning Around Equipment

The position of the spotters/flaggers around equipment is critical to their safety and awareness of hazards.

Positioning **DO's** for Spotters and Flaggers:

- Watch where you are walking/standing.
- Stand in a highly visible location. Discuss the best place to stand with the operator.
- Give consistent, clear, and understandable hand signals.
- Always make sure the operator/driver can see you.
- STOP work if you lose visual contact or communication with the operator/driver.
- STOP work if you need to leave your post.
- Have another trained spotter/flagger ready to take your place if you need a break.

Positioning **DON'TS** for Spotters and Flaggers

Don't

- Position yourself in a struck-by, caught between, or line of fire situation.
- Leave the view of the driver/operator without first stopping the vehicle or equipment.
- Lean on equipment or vehicles while the motor is running.

Don't

- Walk close to a vehicle or piece of equipment while it is moving.
- Assume that an operator/driver knows what you are thinking.
- Leave your post without another spotter/flagger in position to take your place.

Cajun uses the “360 Program” and defined “No Zones” as best practices to help operators, drivers, spotters, and flaggers be more aware of their surroundings and the hazards they are exposed to.

No Zones



No Zones

- The No Zone is the area around equipment or vehicles where people or objects are **NOT VISIBLE** to the operator or driver.
- The Spotter and Flagger should **NEVER** be in the No Zone while the equipment or vehicle is in operation.
- The shaded area around equipment or vehicle seen on the next three pages represents the “No Zone”.

Equipment No Zones

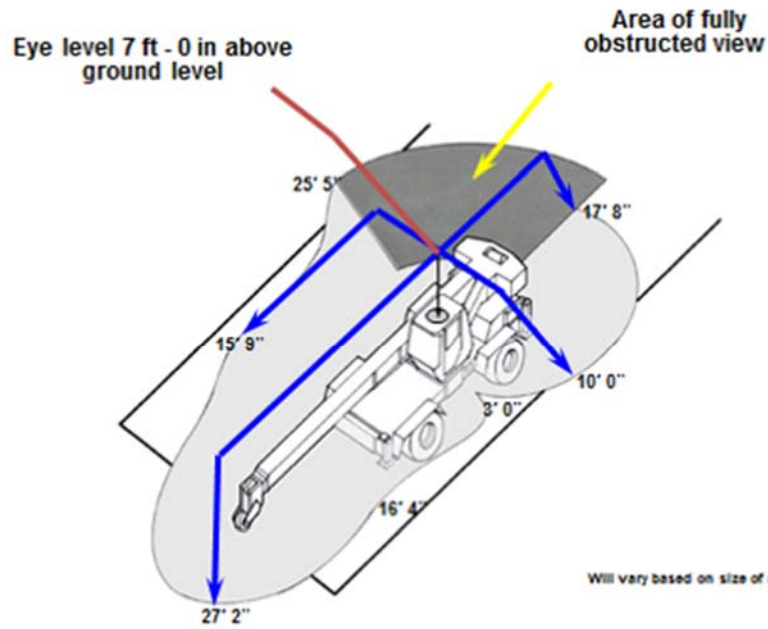

Hydraulic Crane

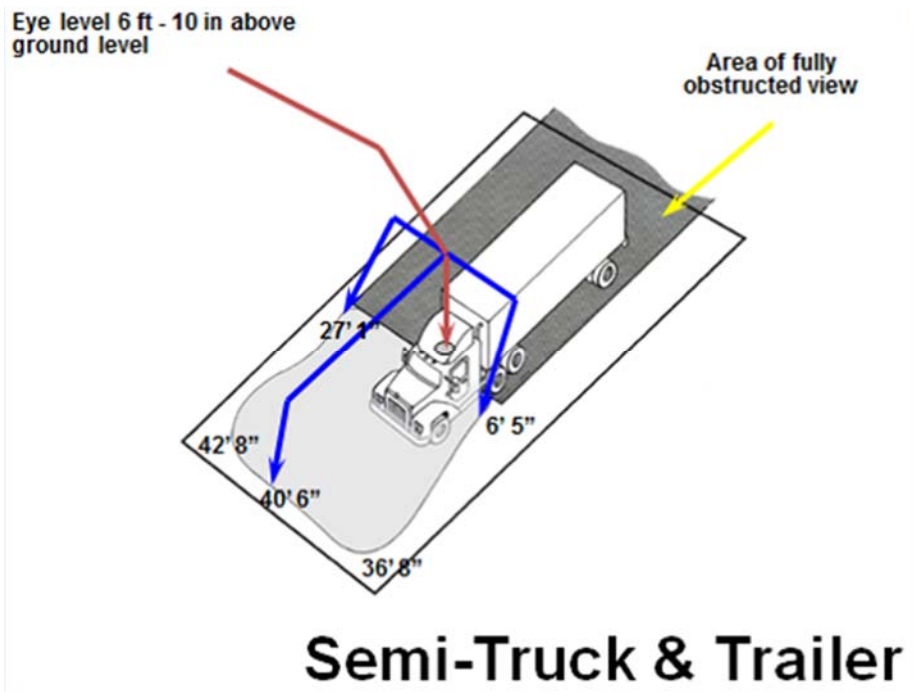

Semi-Truck & Trailer

Equipment No Zones

Eye level 10 ft - 0 in above ground level

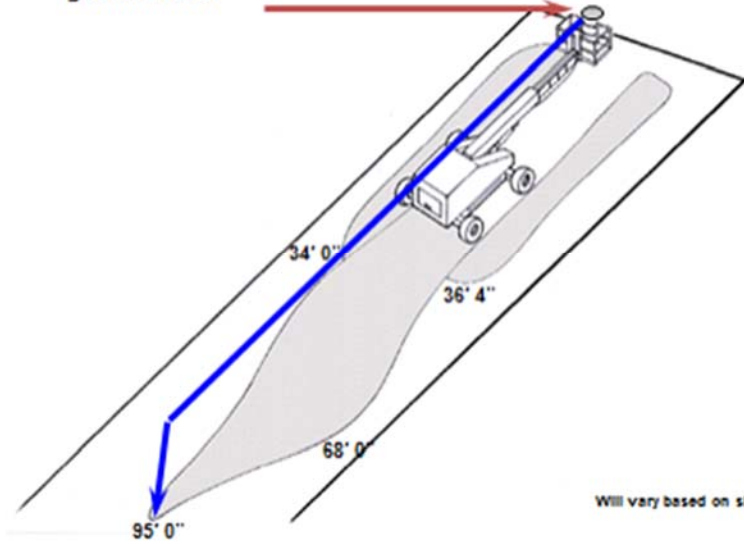

Manlift

Eye level 7 ft - 7 in above ground level

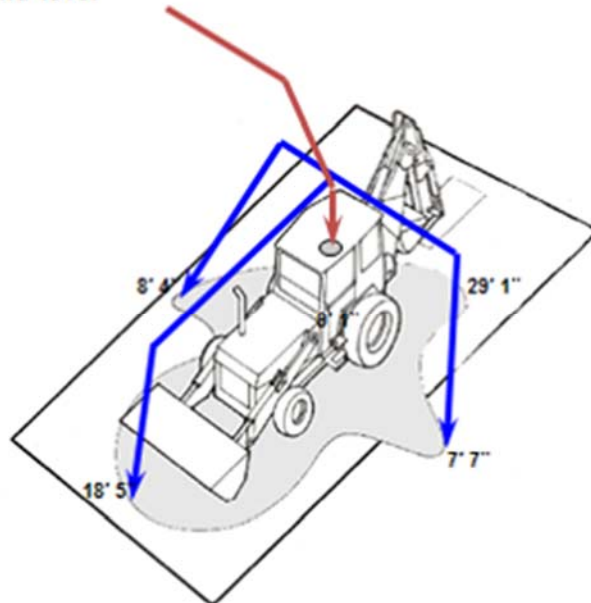

Backhoe

Equipment No Zones

Eye level 7 ft - 3 in above ground level

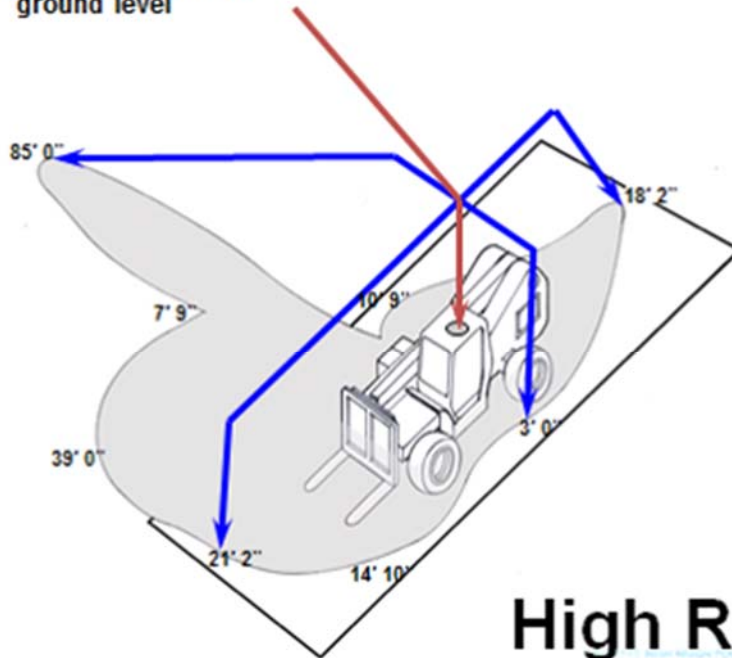

**High Reach
RT Fork Lift**

Eye level 5 ft - 5 in above ground level

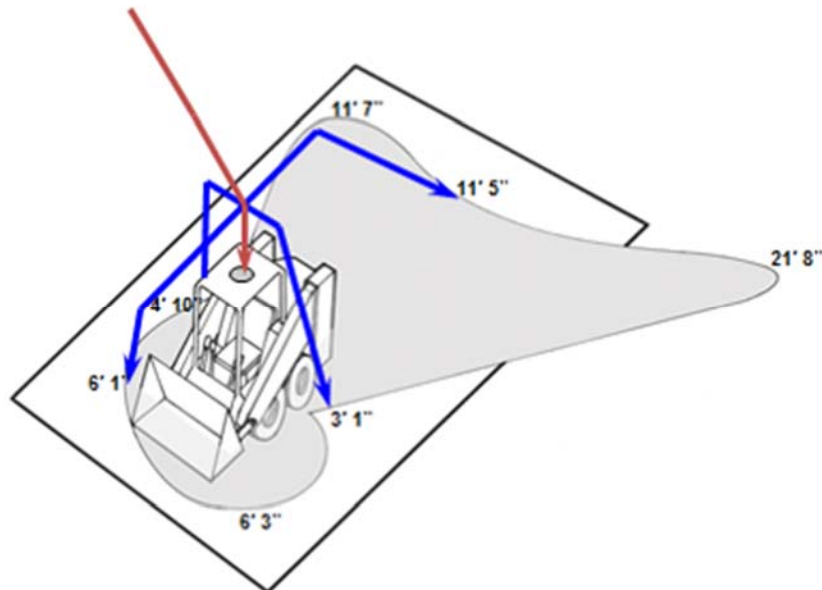

Bobcat/Skid Steer

DOCUMENT ACKNOWLEDGEMENT FORM

Document Name: (please print neatly)	
Date: (please print neatly)	<i>By signing, I acknowledge the information in this document and agree to work in accordance with it</i>
	<input type="checkbox"/> New Training <input type="checkbox"/> Refresher Training

	PRINT NAME	SIGNATURE	JOB #	EMPLOYEE # or SS#
1				
2				
3				
4				
5				
6				
7				
8				
9				
10				
11				
12				
13				
14				
15				
16				
17				
18				
19				
20				
21				
22				
23				
24				
25				
26				
27				
28				
29				
30				